

DESCRIPTION

50 Hz

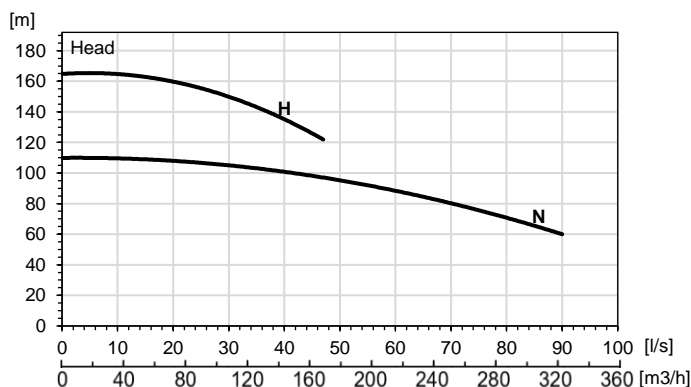

*Referential image



50 Hz

H

N

Power , [kW / HP]	93 / 125	93 / 125
Voltage,V	380 / 400 / 500	380 / 400 / 500
Nominal current, A	161 / 153 / 122	161 / 153 / 122
Weight, kg	1300	1300
Max. height, mm	1681	1681
Max. width, mm	619	619
Discharge, in.	6"	8"
Strainer opening Ø,mm	12	12

Electric submersible drainage pump, available in cast iron and stainless-steel alloys. Design for mining application, power plants and other industries that handle abrasive solids and water.

Models:

N: Normal pressure.

H: High pressure.

Classification

Submersible electric pump

Electric motor

Three-phase squirrel cage motor, 2 poles.

Speed: 2950 RPM

Insulation class: H

Start: Star-Delta, Soft Starter

Max. number of starts per hour: 12

Motor protection

Thermo-contacts in the winding.

Protection: IP 68

Cable

2 cables 4G35 +2x1.5mm², 20m (*).

This pump must be connected to an external electrical cabinet with adequate protections.

Mechanical seals

Double mechanical seal in oil chamber and water.

Rotary seal material: silicon carbide.

Stationary seal material: silicon carbide.

Elastomers: Viton.

Bearings

Lower: Angular contact bearing.

Upper: Cylindrical roller bearing.

Discharge connection

6" H - 8" N. (*)

Limitations

Maximum submersion: 50m.

Maximum liquid temperature: 40 ° C (104 ° F)

Liquid pH range: 2-11

Available Materials

Cover: Stainless steel.

Cylinder: Stainless steel.

Strainer: Stainless steel.

Impeller: Stainless steel.

Diffusers: Stainless steel + PU.

Shaft: AISI 431 Stainless steel.

Screws / Nuts: Stainless steel.

**Specifications may be modified without prior*

50 Hz

Performance curves

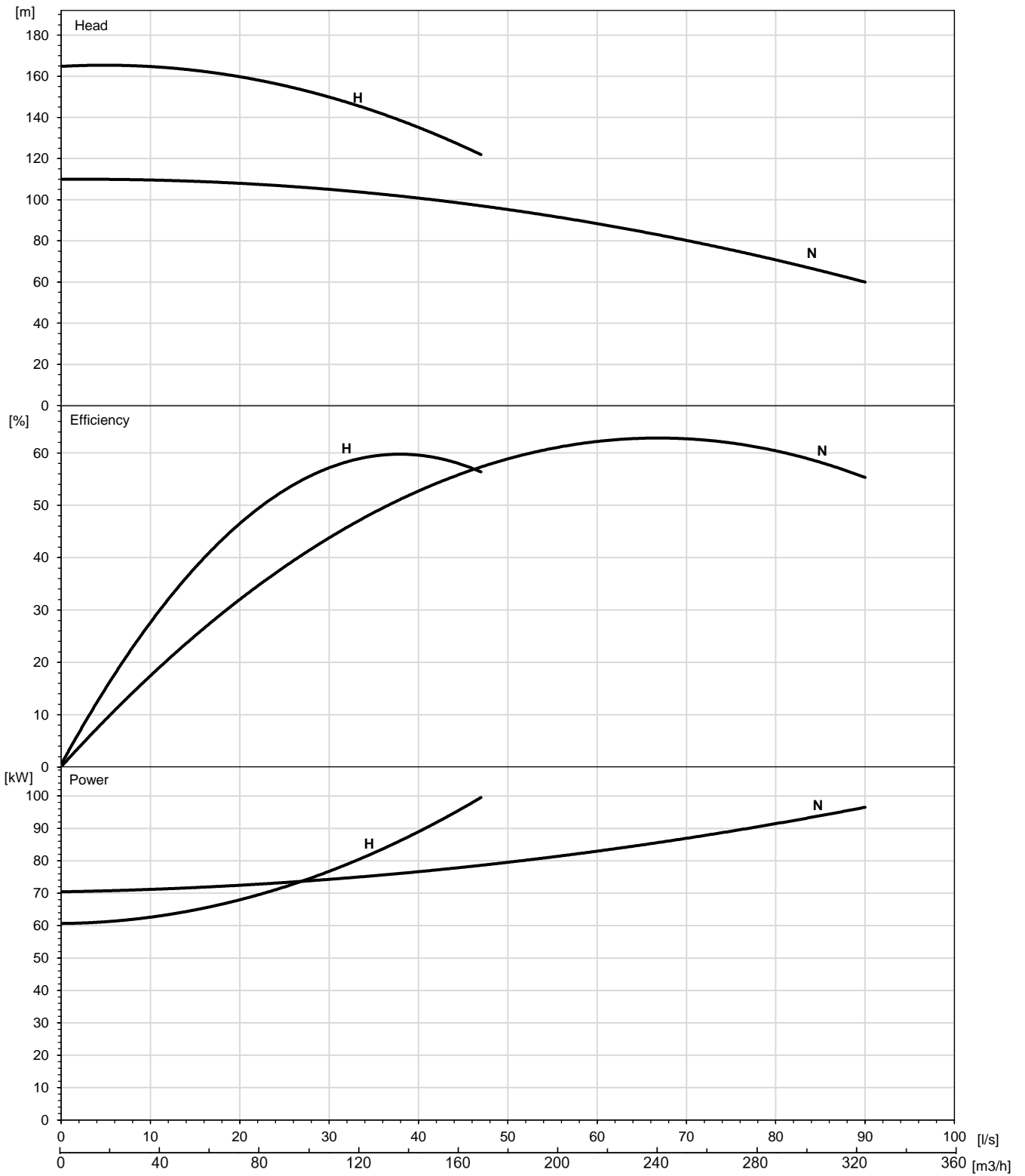

Curve: ISO 9906

H / N

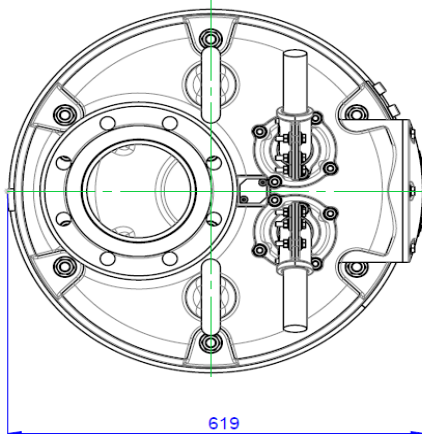
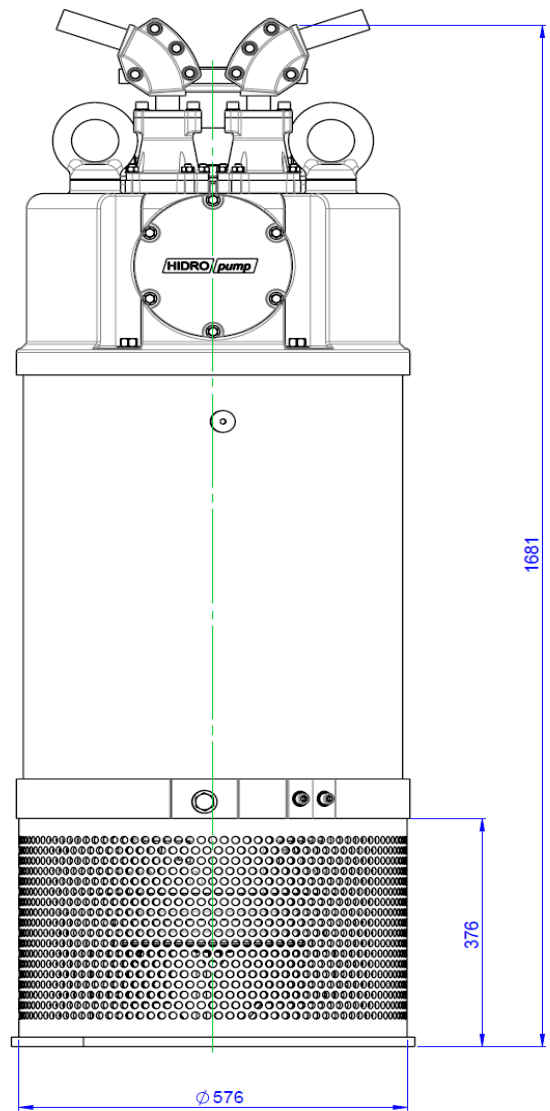
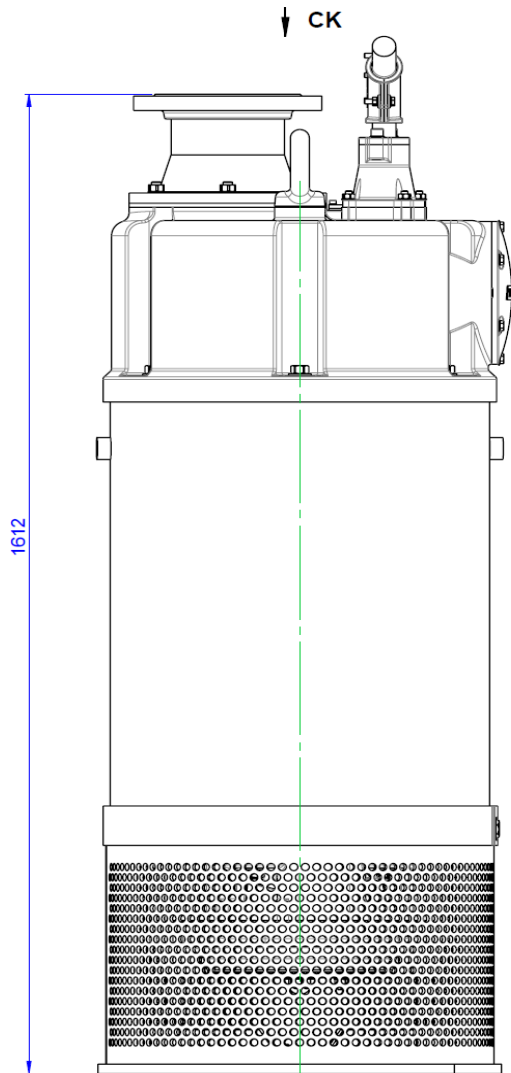

VISTA CK

NOTE:
-REFERENTIAL MEASURES.
-DESCHARGUE ON REQUEST.