

DESCRIPTION

60 Hz

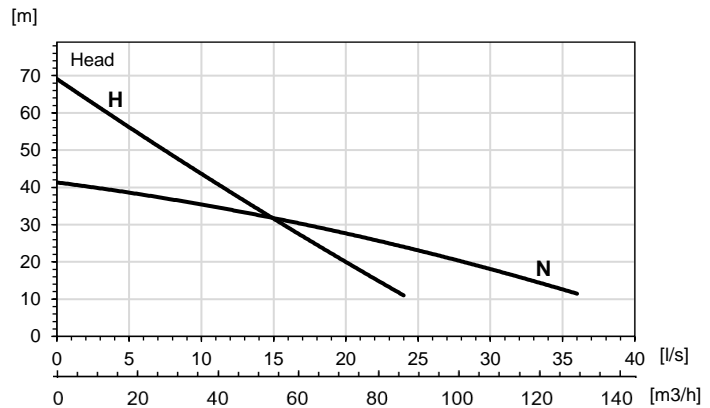

*Referential image



60 Hz

H

N

Power , [kW / HP]	11 / 15	11 / 15
Voltage,V	380 / 440 /460	380 / 440 / 460
Nominal current,A	21,8 / 18,8 / 18	21,8 / 18,8 / 18
Weight, kg	158	158
Max. height, mm	891	891
Max. width, mm	342	342
Discharge, in	3"	4"
Strainer opening Ø,mm	7	7

Electric submersible drainage pump, available in various aluminum and stainless-steel alloys. For applications in mines, power plants and other industries that handle abrasive solids and water.

Models:

N: Normal pressure.
H: High pressure.

Classification

Submersible electric pump

Electric motor

Three-phase squirrel cage motor
Speed: 3550 RPM
Insulation class: H
Start: Direct
Max. number of starts per hour: 12

Motor protection

Three-phase squirrel cage motor
Protection: IP 68

Cable

4G10 + 2x1.5mm², 20m. (*)

This pump must be connected to an external electrical cabinet with adequate protections.

Mechanical seals

Double mechanical seal in oil chamber and water.
Rotary seal material: Silicon carbide.
Stationary seal: Silicon carbide.
Elastomers: Viton.

Bearings

Deep groove ball bearing C3.

Discharge connection

3" H – 4" N. (*)

Limitations

Maximum submersion: 20 m.
Maximum liquid temperature: 40 °C (104 °F)
Liquid pH range: 2 – 11.

Available materials

Cover: Stainless steel.
Cylinder: Stainless steel.
Strainer: Stainless steel.
Impeller: Stainless steel.
Diffusers: Stainless steel +PU.
Shaft: AISI 431 Stainless steel.
Screws/Nuts: Stainless steel.

**Specifications may be modified without prior*

60 Hz

Performance curves

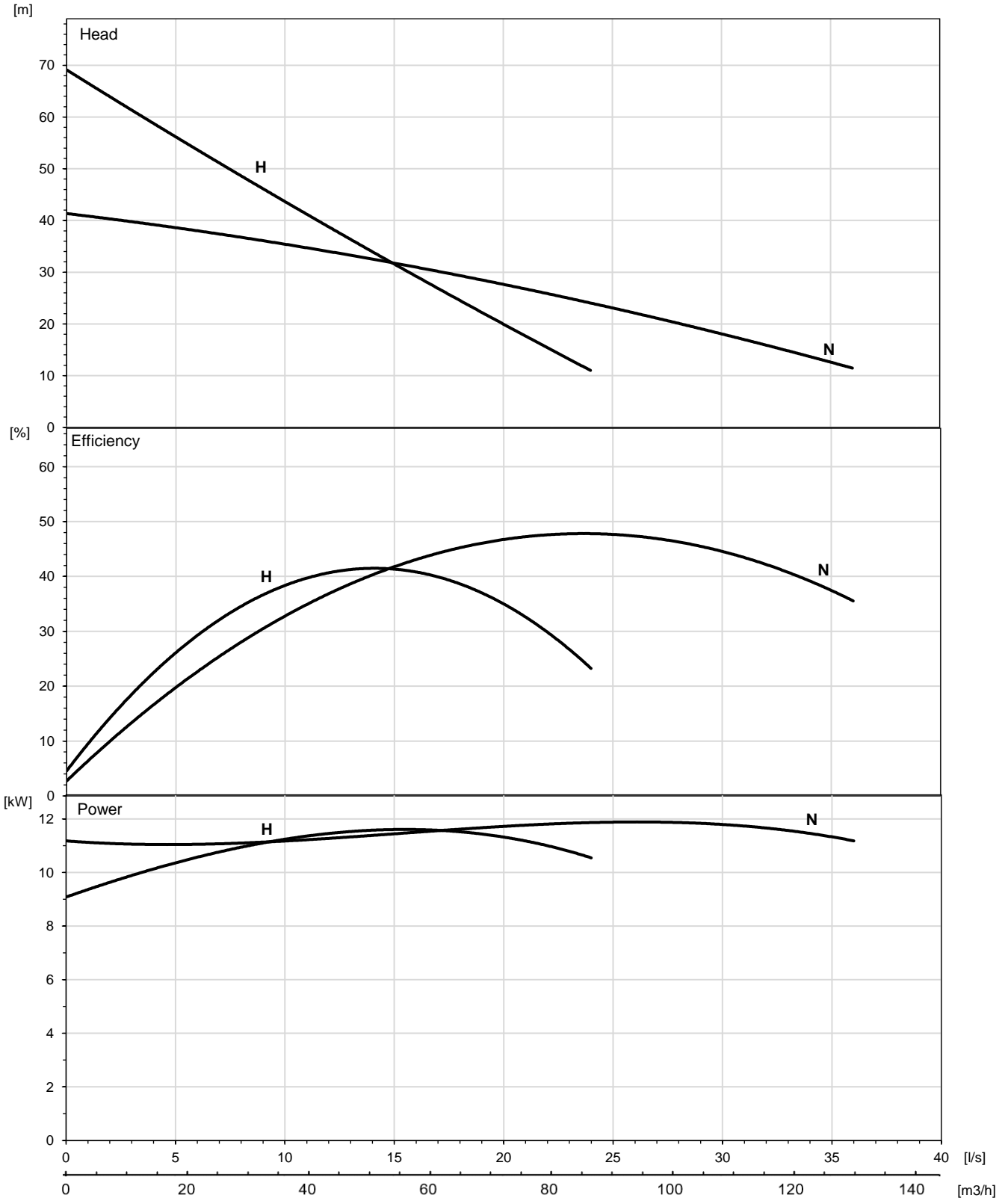

Curve: ISO 9906

H / N

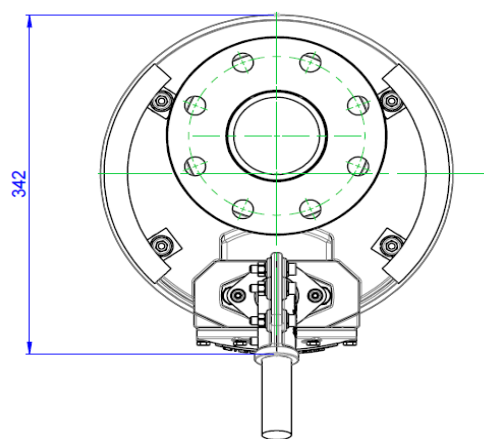
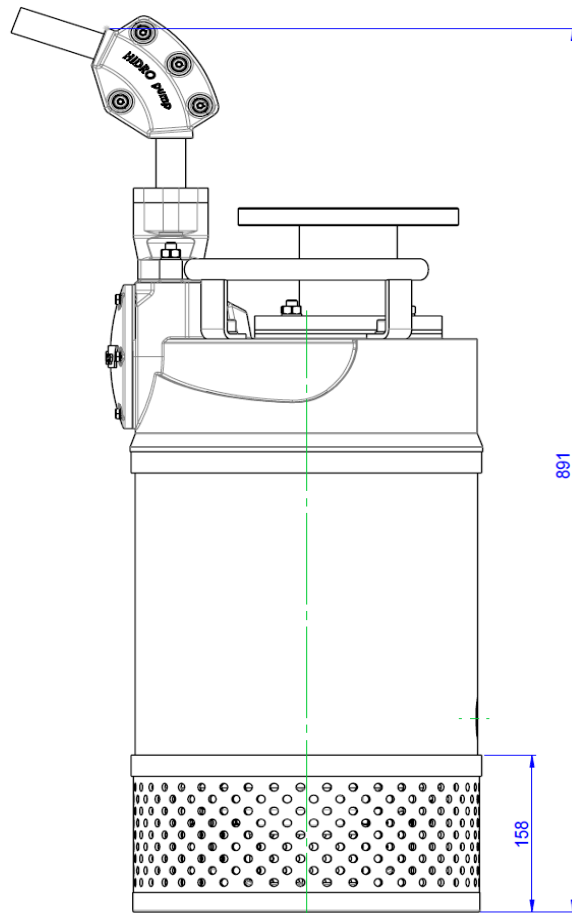
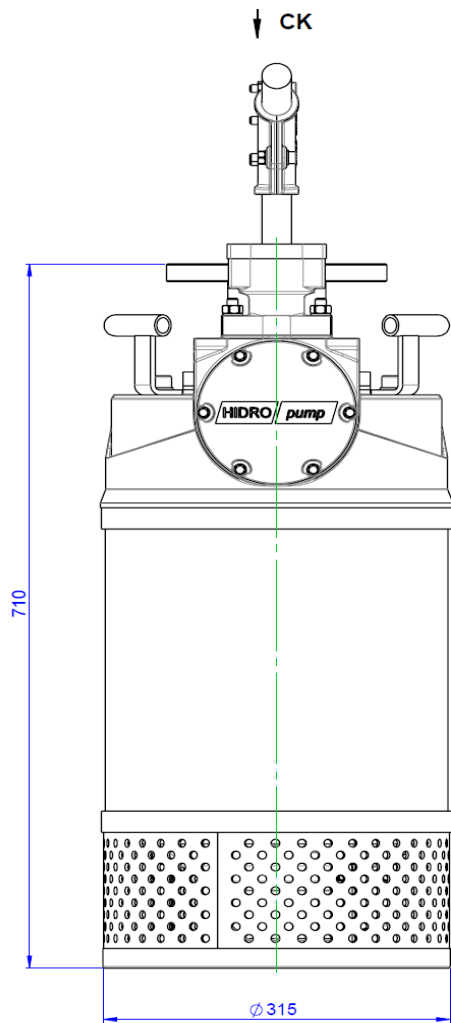

VISTA CK

NOTE:
-REFERENTIAL MEASURES.
-DESCARGUE ON REQUEST.